

TASCHEN-MESSSCHIEBER MIT FESTSTELLRAD, DIN 862

VERNIER CALIPER WITH SETTING WHEEL, DIN 862

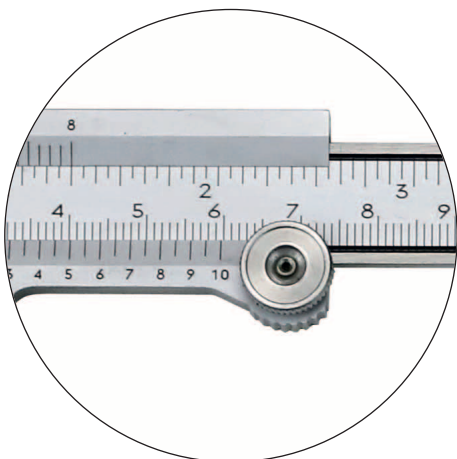
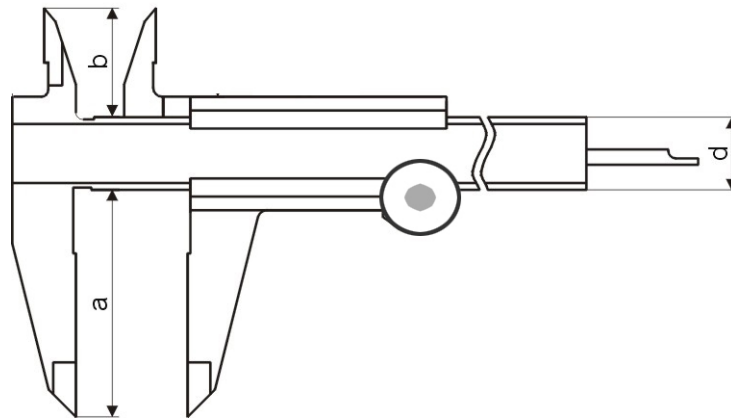
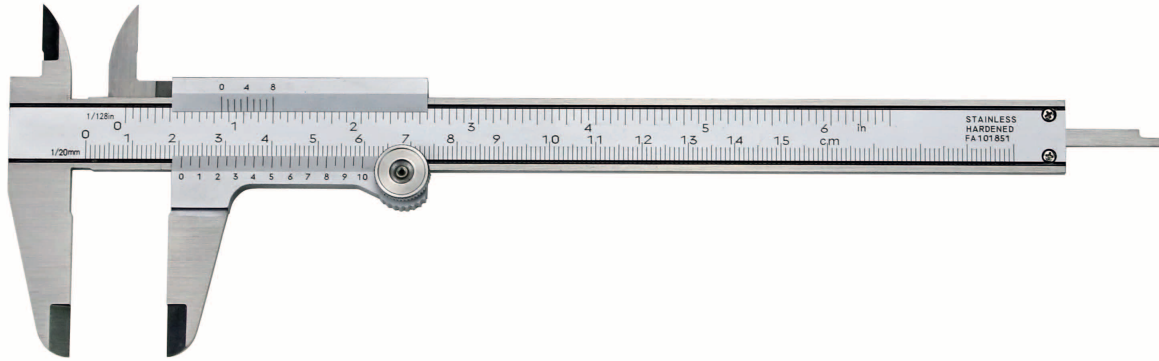

- mit Feststellrad
- aus rostfreiem Stahl
- mattverchromt, ganz gehärtet
- für 4-fach Messung geeignet
- Rückseite mit Gewindetabelle
- im Behältnis/Kasten

- *with setting wheel*
- *made of stainless steel*
- *satin chrome finished, hardened*
- *usable to 4-way measurement*
- *backside with screw table*
- *in case/box*

Art.-Nr. <i>Item no.</i>	Messbereich <i>Range mm</i>	Feststellung <i>Locking</i>	Nonius unten <i>Nonius below mm</i>	Nonius oben <i>Nonius - above mm</i>	a <i>mm</i>	b <i>mm</i>	d <i>mm</i>
201.051	150	<i>Stellrad / set wheel</i>	1/20 - 39	1/128"	40	17	16