

MESSUHR, 30 MM UND 50 MM

DIAL INDICATOR, 30 MM AND 50 MM



208.007



208.006

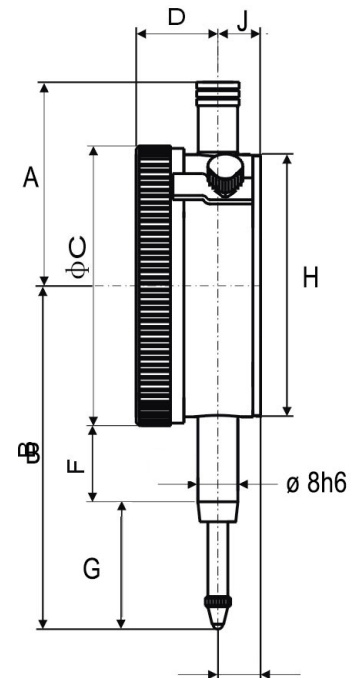

- Genauigkeit nach Werksnorm
- Metallgehäuse
- mit Toleranzmarken
- Aufnahme Ø 8 h6
- Ziffernblatt durch Außenring drehbar

- *accuracy according to manufacture standard*
- *metal casing*
- *with tolerance marks*
- *shank Ø 8 h6*
- *dial face rotatable by outer ring*

Art.-Nr. <i>Item no.</i>	Messbereich <i>Range mm</i>	Ablesung <i>Reading mm</i>	Genauigkeit <i>Accuracy µm</i>	Außenring <i>Dial diameter mm</i>	A+B <i>mm</i>	F <i>mm</i>	G <i>mm</i>	H <i>mm</i>
208.007	30	0,01	34	58	122	18	33	53,5
208.006	50	0,01	55	60	257	55	62	55,0