

DIGITAL-WERKSTATT-MESSSCHIEBER MIT SPITZEN

DIGITAL CONTROL CALIPER WITH POINTS

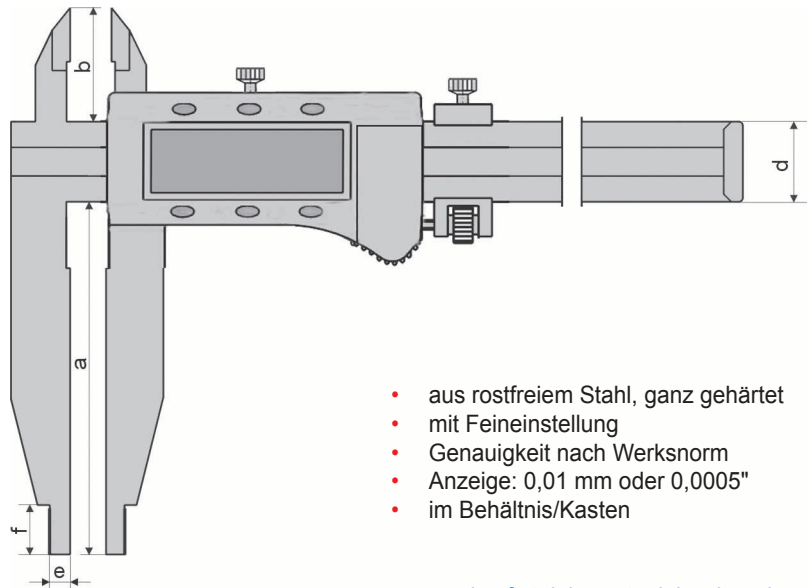

- aus rostfreiem Stahl, ganz gehärtet
- mit Feineinstellung
- Genauigkeit nach Werksnorm
- Anzeige: 0,01 mm oder 0,0005"
- im Behältnis/Kasten

- *made of stainless steel, hardened*
- *with fine adjustment*
- *accuracy manufacture standard*
- *reading: 0,01 mm or 0,0005"*
- *in case/box*

- Messsystem mit 3 V
- mit Ein/Aus-, mm/inch-, 0/Abs, Hold-, Tol- und Preset-Tasten
- Datenausgang (RB 5)

- *Measuring system with 3 V*
- *with on/off, mm/inch, 0/abs and zero/preset button*
- *Data output (RB 5)*



Art.-Nr. <i>Item no.</i>	Messbereich <i>Range mm</i>	Schnabellänge <i>Jaws a mm</i>	Genauigkeit <i>Accuracy mm</i>	b <i>mm</i>	d <i>mm</i>	e <i>mm</i>	f <i>mm</i>	kg
217.044	500	150	0,05	56	24	10	18	1,2
217.048	600	150	0,06	56	24	10	18	1,3
217.049	600	300	0,08	56	42	10	24	5,0
217.048.1	800	150	0,06	67	31	10	24	2,6
217.045	1000	150	0,07	67	31	10	24	2,7
217.046	1500	200	0,10	80	42	10	24	6,3
217.047	2000	200	0,12	80	42	10	24	7,8