

DIGITAL-TIEFEN-MESSSCHIEBER MIT STIFTSPITZE Ø 1,5 x 6 mm, DIN 862

DIGITAL DEPTH CALIPER WITH NEEDLE POINT Ø 1.5 x 6 mm, DIN 862

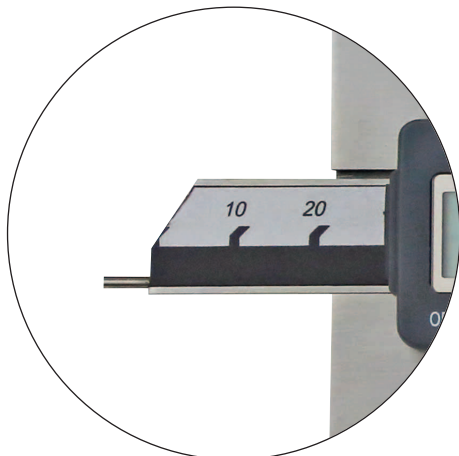
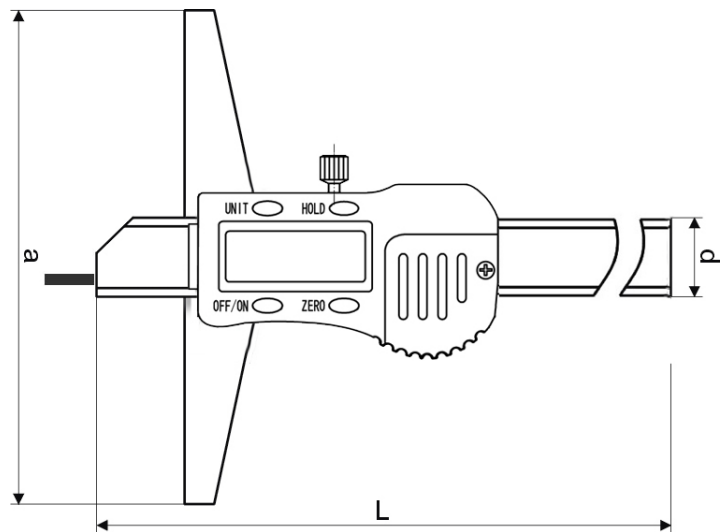
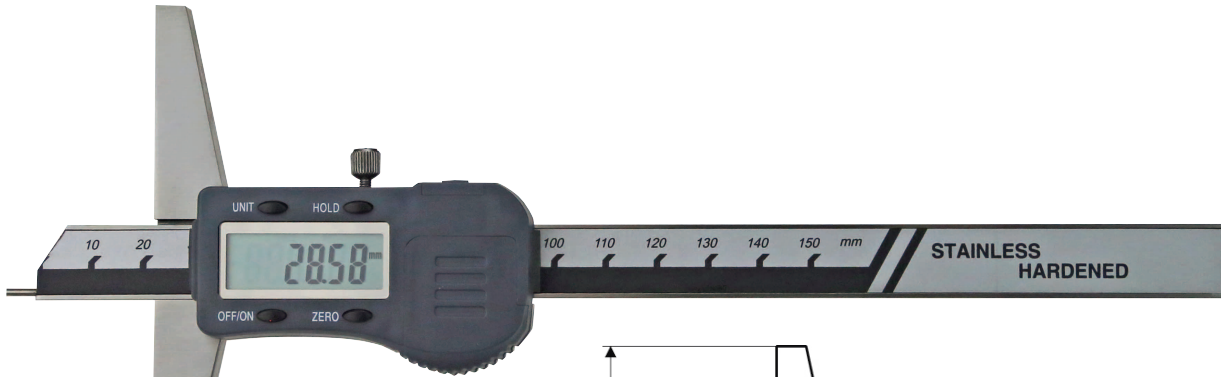

- mit Stiftspitze \varnothing 1,5 x 6 mm
- aus rostfreiem Stahl, gehärtet
- Elektronik mit 3 V System
- mit Ein/Aus-, Null-, Unit- und Hold-Taste
- mit RS 232C-Schnittstelle (RB5)
- Ablesung 0,01 mm/0,0005"
- Genauigkeit DIN 862
- im Behältnis/Kasten

- *with needle point \varnothing 1.5 x 6 mm*
- *made of stainless steel, hardened*
- *electronic with 3 V system*
- *with on/off, zero, unit and hold button*
- *with RS232C data output (RB5)*
- *reading 0.01 mm or 0.0005"*
- *accuracy DIN 862*
- *in case/box*

Art.-Nr. <i>Item no.</i>	Messbereich <i>Range mm</i>	Brückenlänge <i>Base a mm</i>	d <i>mm</i>
218.085.1	150	100	16
218.085.N	200	100	16
218.087.N	200	150	16
218.086.N	300	100	16
218.088.N	300	150	16