

**DIGITAL-BÜGELMESSSCHRAUBEN MIT GROSSEM MESSBEREICH**  
*DIGITAL MICROMETER WITH LARGE MEASURING RANGE*

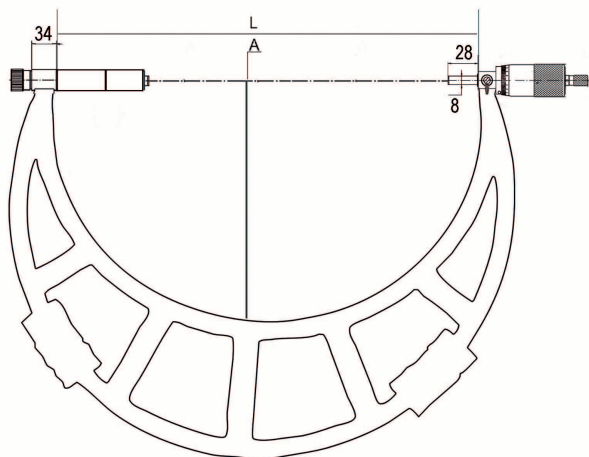
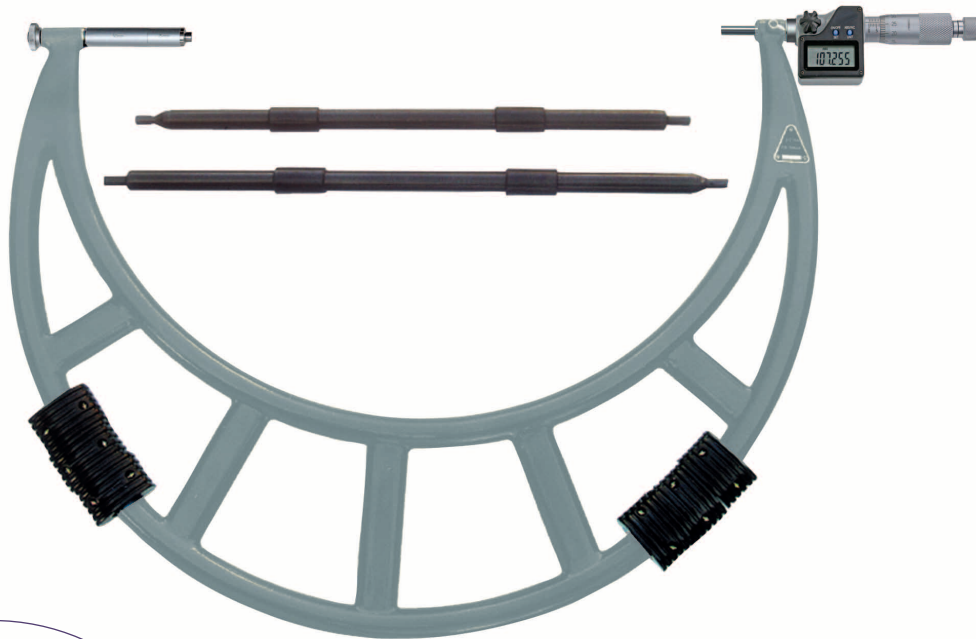

- mit auswechselbaren Messambossen
- mit HM-Messflächen, Messspindel Ø 8,0 mm
- Messtrommel mattverchromt
- Spindelsteigung 0,5 mm
- mit Ratsche und Einstellmaßen
- Digital-Anzeige mit ON/OFF/SET-, ABS/INC- UNIT-Taste
- Ablesung 0,001 mm
- Genauigkeit Werknorm
- im Behältnis/Kasten

- *with exchangeable anvils*
- *with carbide measuring faces, spindle Ø 8.0 mm*
- *thimble chrome finished*
- *thread pitch 0.5 mm*
- *with ratchet and setting standard*
- *display with ON/OFF/SET, ABS/INC/UNIT button*
- *reading 0.001 mm*
- *accuracy manufacture standard*
- *in case/box*

Art.-Nr. <i>Item no.</i>	Messbereich <i>Range mm</i>	Genauigkeit <i>Accuracy mm</i>	Amboss/St. <i>Anvils/pcs</i>	Einstellmaß <i>Standard mm</i>	A <i>mm</i>	L <i>mm</i>	kg
<b>302.026.C</b>	300 - 400	0,011	25 + 50	325 + 375	244	417	1,7
<b>302.027.C</b>	400 - 500	0,013	25 + 50	425 + 475	292	520	2,0
<b>302.028.C</b>	500 - 600	0,015	25 + 50	525 + 575	321	609	2,2