

**DIGITAL-EINBAU-MESSSCHRAUBEN, DIN 863**

*DIGITAL MICROMETERS HEAD, DIN 863*

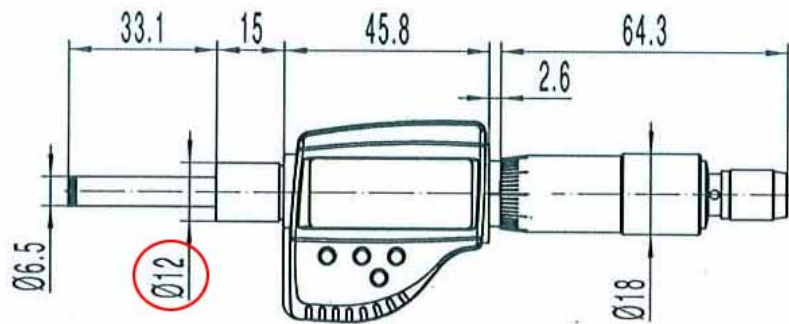

- mit HM-Messflächen
- Messspindel  $\varnothing$  6,5 mm
- mit Ratsche
- Aufnahme 12 h7
- Digital-Anzeige mit ON/0-, mm/inch-, ABS- und HOLD-Taste
- Ablesung 0,001 mm
- mit Datenausgang RB 4

- *with carbide measuring face*
- *spindle  $\varnothing$  6.5 mm*
- *with ratchet*
- *shank 12h7*
- *display with ON/0-, mm/inch-, ABS and HOLD button*
- *reading 0.001 mm*
- *with data output RB 4*

Art.-Nr. <i>Item no.</i>	Messbereich <i>Range mm</i>	Messfläche <i>Meas. face</i>	Genauigkeit <i>Accuracy mm</i>
302.091.G	0 - 25	planparallel - flat	0,004