

**BÜGELMESSSCHRAUBEN ZUR NUTENMESSUNG**

*BLADE MICROMETER*

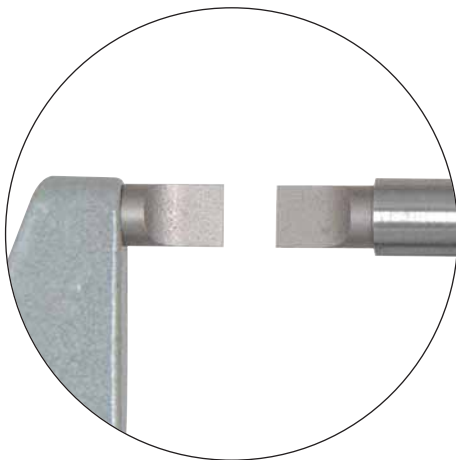
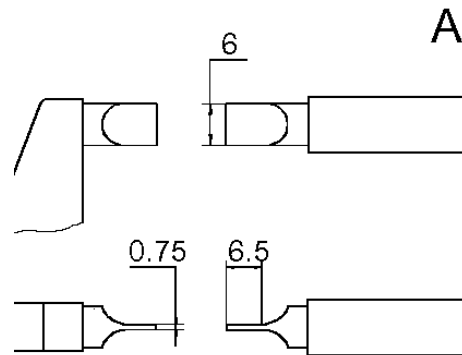
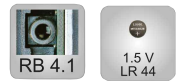

- mit nichtdrehender Messspindel  $\varnothing$  6,5 mm
- Spindelsteigung 0,5 mm
- Messfläche 0,75 mm x 6,5 mm
- mit Ratsche
- Digital-Anzeige mit ON/OFF-, ABS/INC-, UNIT- und SET-Taste
- Ablesung 0,001 mm / 0,00005"
- mit Datenausgang RB 4.1
- ab 25 mm inkl. Einstellmaß, im Behältnis/Kasten

- *spindle: non-rotating,  $\varnothing$  6.5 mm*
- *thread pitch 0.5 mm*
- *with measuring faces 0.75 mm x 6.5 mm*
- *with ratchet*
- *display with ON/OFF, ABS/INC, UNIT and SET button*
- *reading 0.001 mm or 0.00005"*
- *with data output RB 4.1*
- *from 25 mm incl. setting standard, in case/box*

Art.-Nr. <i>Item no.</i>	Messbereich <i>Range mm</i>	Genauigkeit <i>Accuracy mm</i>
302.121.C	0 - 25	0,005
302.122.C	25 - 50	0,005