

DIGITAL-MESSSCHRAUBEN MIT HM-SPITZEN, 2 MM SPINDELSTEIGUNG

DIGITAL MICROMETER WITH CARBIDE POINTS, 2 MM SPINDLE

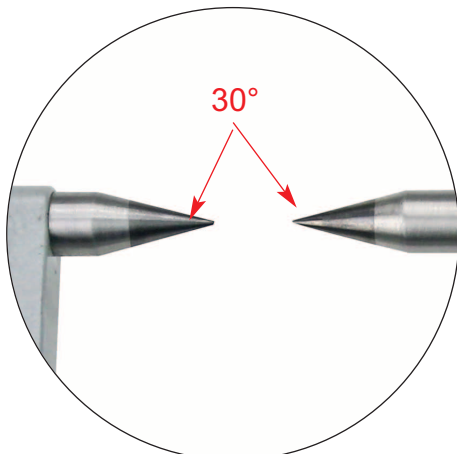
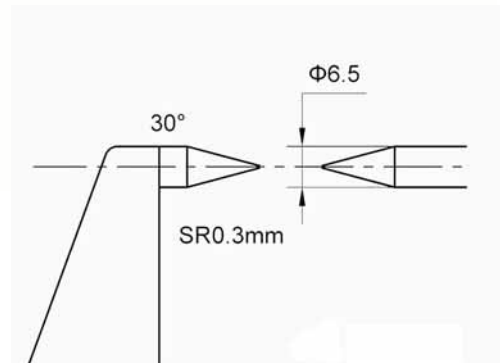

- Bügel lackiert
- mit HM-Messspitzen
- Spindelsteigung 2 mm, mit Friktionsratsche
- Digital-Anzeige mit ON/OFF/SET-, ABS/INC/UNIT-Taste
- Ablesung: 0,001 mm
- Genauigkeit: 0,005 mm
- im Behältnis/Kasten

- *frame coated*
- *carbide measuring points*
- *spindle 2 mm/U, with friction ratchet*
- *display with ON/OFF/SET, ABS/INC/UNIT button*
- *reading: 0.001 mm*
- *accuracy: 0.005 mm*
- *in case/box*

- mit HM-Messspitzen Ø 6,5 mm x 30°

- *with carbide measuring points Ø 6.5 mm x 30°*

Art.-Nr. <i>Item no.</i>	Messbereich <i>Range mm</i>	Messspitze <i>Meas. points mm</i>
302.214	0 - 25	30°