

BÜGELMESSSCHRAUBEN MIT AUSWECHSELBAREN AMBOSSEN
MICROMETER WITH EXCHANGEABLE ANVILS

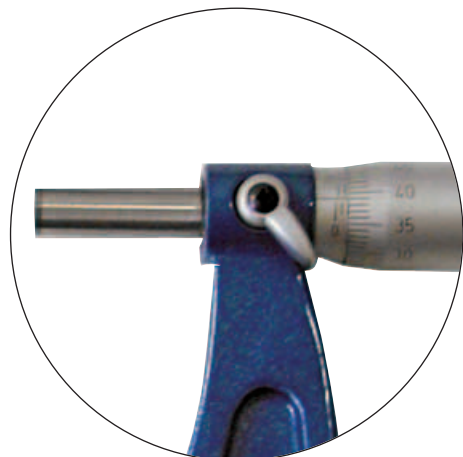
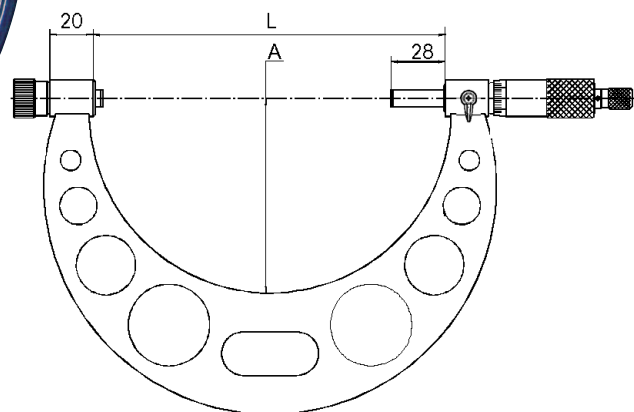
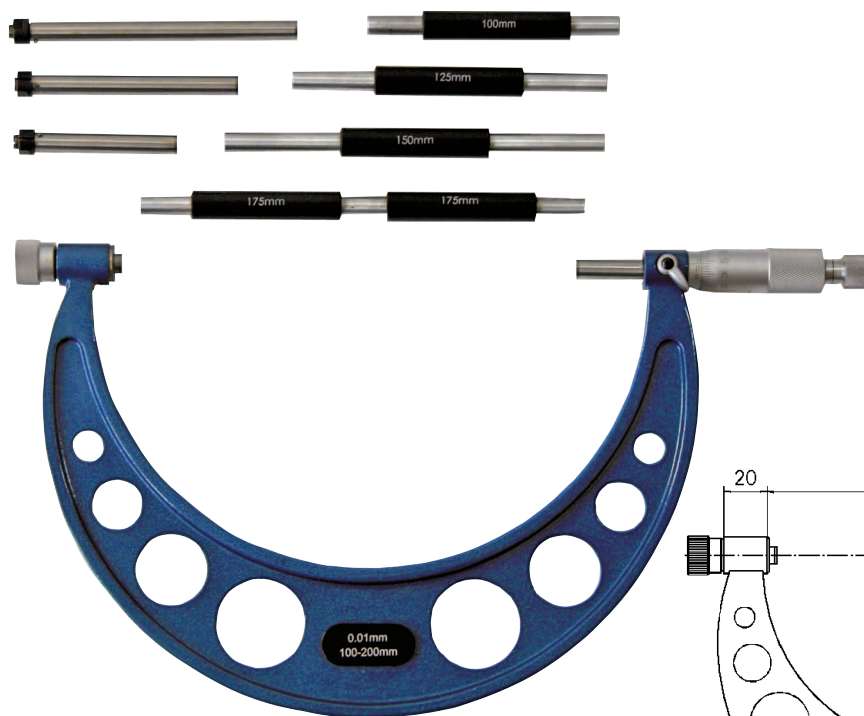

- mit auswechselbaren Messambossen
- mit HM-Messflächen
- Messspindel Ø 8,0 mm
- Messtrommel mattverchromt
- Spindelsteigung 0,5 mm
- mit Ratsche und Einstellmaßen
- Ablesung 0,01 mm
- Genauigkeit nach Werksnorm
- im Behältnis/Kasten

- *with exchangeable anvils*
- *with carbide measuring faces*
- *spindel Ø 8.0 mm*
- *thimble chrome finished*
- *thread pitch 0.5 mm*
- *with ratchet and setting standard*
- *reading 0.01 mm*
- *accuracy manufacture standard*
- *in case/box*

Art.-Nr. <i>Item no.</i>	Messbereich <i>Range mm</i>	Genauigkeit <i>Accuracy mm</i>	Amboss/St. <i>Anvils/pcs</i>	Einstellmaß <i>Standard mm</i>	A <i>mm</i>
304.028	0 - 100	0,009	4	25/50/75	57
304.029	100 - 200	0,011	4	100/125/150/175	114
304.030	200 - 300	0,013	4	200/225/250/275	165
304.031	0 - 150	0,011	6	25/50/75/100/125	82
304.032	150 - 300	0,013	6	150/175/200/225/250/275	165