

BÜGELMESSSCHRAUBEN MIT TELLERMESSFLÄCHEN UND NICHT DREHENDER SPINDEL
DISC MICROMETER WITH NON-ROTATING SPINDLE

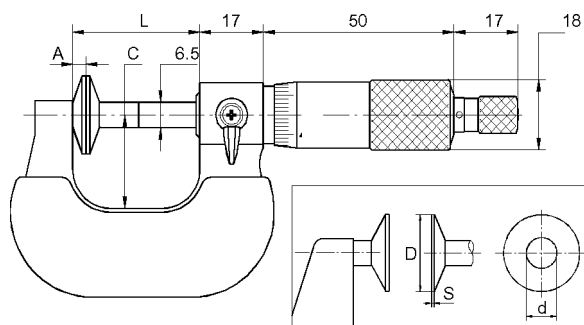
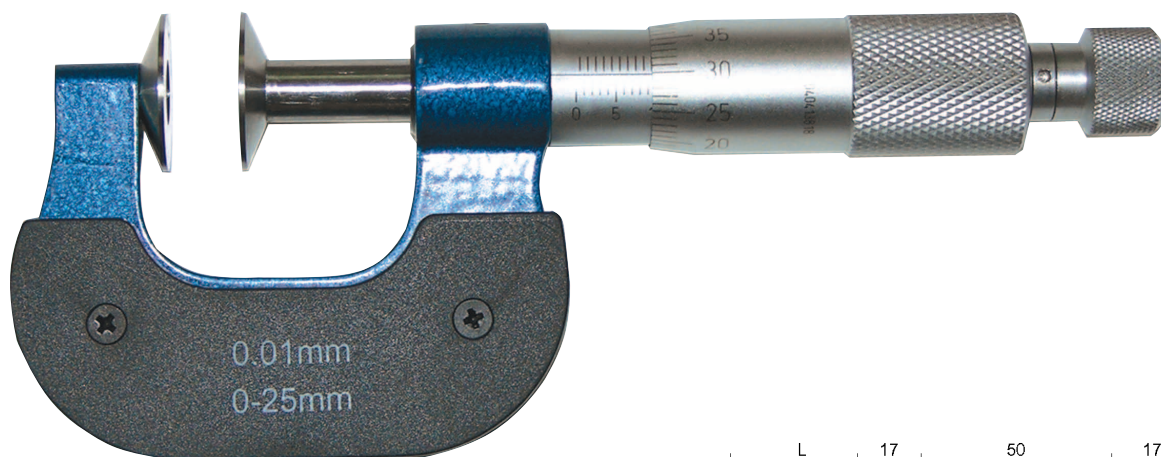

- mit nicht drehender Spindel
- Bügel lackiert
- Messtrommel mattverchromt
- im Behältnis/Kasten

- *Disc micrometers with non-rotating spindle*
- *frame coated*
- *thimble chrome finished*
- *in case/box*

- Ablesung 0,01 mm; mit Ratsche
- *reading 0.01 mm; with ratchet*

Art.-Nr. <i>Item no.</i>	Messbereich <i>Range mm</i>	Messteller <i>Disc mm</i>	Genauigkeit <i>Accuracy mm</i>	A <i>mm</i>	C <i>mm</i>	L <i>mm</i>	d <i>mm</i>	S <i>mm</i>
309.250	0 - 25	20	0,004	8	32	43	8	0,7
309.251	25 - 50	20	0,004	8	44	68	8	0,7
309.252	50 - 75	20	0,005	8	57	93	8	0,7
309.253	75 - 100	20	0,005	10	57	118	8	0,7
309.350	0 - 25	30	0,004	8	32	43	8	0,7
309.351	25 - 50	30	0,004	8	44	68	8	0,7
309.352	50 - 75	30	0,005	8	57	93	8	0,7
309.353	75 - 100	30	0,005	10	57	118	8	0,7
309.254	100 - 125	30	0,006	10	70	144	12	0,7
309.255	125 - 150	30	0,006	12	82	169	12	0,7
309.256	150 - 175	30	0,007	12	94	194	12	0,7
309.257	175 - 200	30	0,007	12	120	220	12	0,7