

**DIGITAL-DREIPUNKT-INNEN-MESSSCHRAUBEN, SERIE N**  
*DIGITAL THREE POINT INTERNAL MICROMETER, SERIAL N*

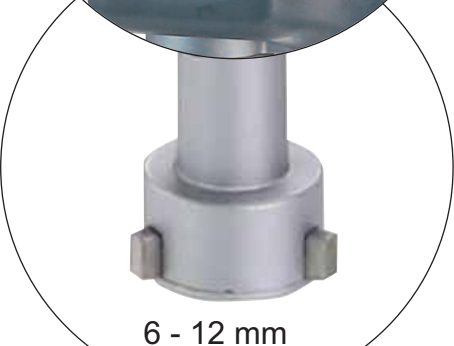

6 - 12 mm

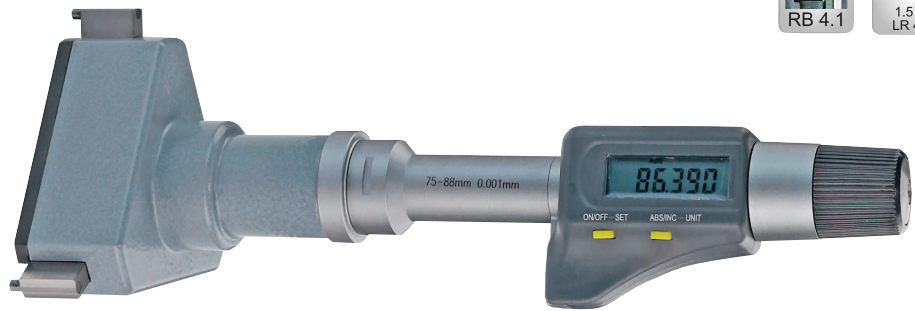
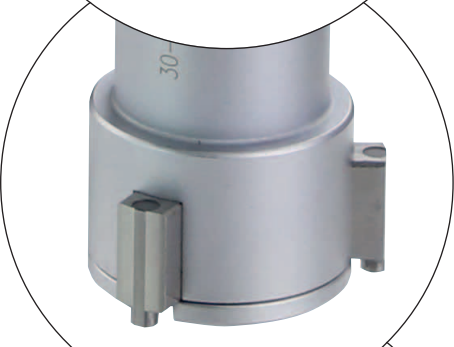

12 - 50 mm

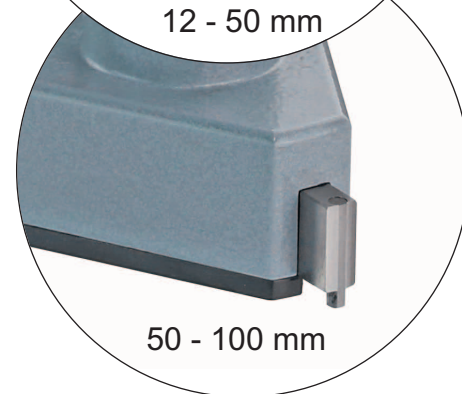

50 - 100 mm

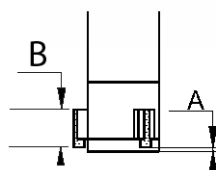
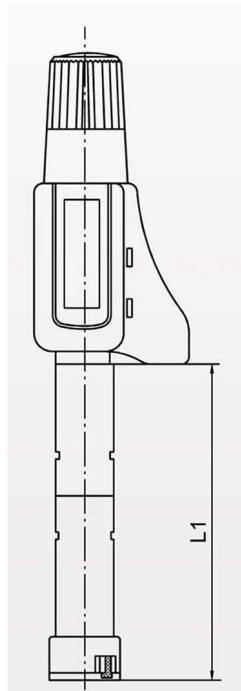

- geeignet zur Messung von Sacklochbohrungen
- mit Hartmetall-Messflächen ab 12 mm
- Skala und Nonius mattverchromt
- mit Einstellung und Verlängerung
- Digital-Anzeige mit ON/OFF/SET- und ABS/INC/UNIT-Taste
- Ablesung 0,001 mm
- mit Datenausgang RB 4.1
- im Behältnis/Kasten

- *for blind hole*
- *with carbide measuring faces from 12 mm*
- *satin chrome finished*
- *with setting gauge and extension*
- *display with ON/OFF/SET and ABS/INC/UNIT button*
- *reading 0.001 mm*
- *with data output RB 4.1*
- *in case/box*

Art.-Nr. <i>Item no.</i>	Messbereich <i>Range mm</i>	Einstellring <i>Standard mm</i>	Verlängerung <i>Extension mm</i>	A <i>mm</i>	L1 <i>mm</i>	Genauigkeit* <i>Accuracy* mm</i>
312.230.N	6 - 8	6	100 x ø 5,7	0,5	55	0,004
312.231.N	8 - 10	8	100 x ø 5,7	0,5	55	0,004
312.232.N	10 - 12	10	100 x ø 5,7	0,5	55	0,004
312.233.N	12 - 16	12	150 x ø 11,7	0,5	80	0,005
312.234.N	16 - 20	16	150 x ø 11,7	0,5	80	0,005
312.235.N	20 - 25	25	150 x ø 16,0	0,5	90	0,005
312.236.N	25 - 30	25	150 x ø 16,0	0,5	90	0,005
312.237.N	30 - 40	30	150 x ø 23,4	0,5	97	0,005
312.238.N	40 - 50	40	150 x ø 23,4	0,5	97	0,005
312.239.N	50 - 63	50	150 x ø 23,4	0,5	114	0,005
312.240.N	62 - 75	62	150 x ø 23,4	0,5	114	0,005
312.241.N	75 - 88	87	150 x ø 23,4	0,5	114	0,005
312.242.N	87 - 100	87	150 x ø 23,4	0,5	114	0,005