

DIGITAL-PISTOLE-DREIPUNKT-INNEN-SCHNELLMESSGERÄT, SATZ

DIGITAL PISTOL THREE POINT INTERNAL GAUGE, SET

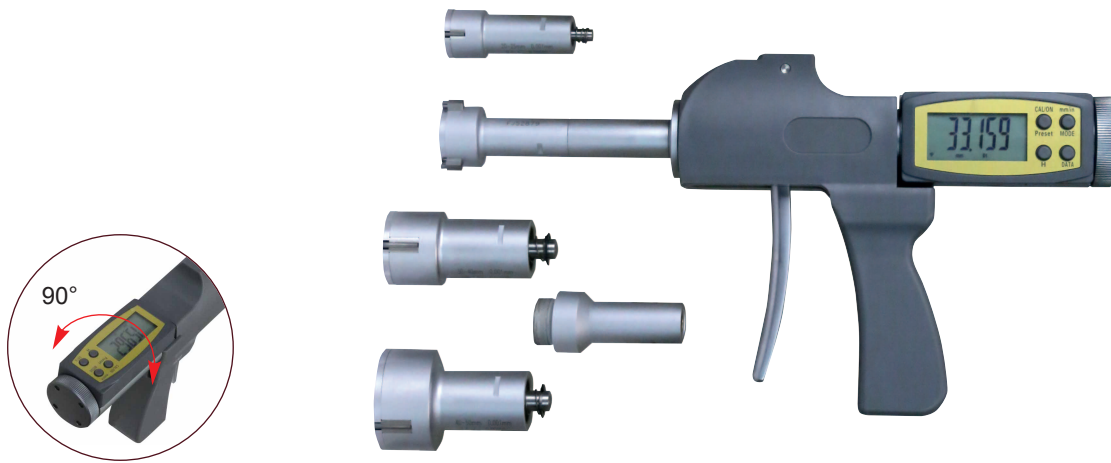

- geeignet zur Messung von Sacklochbohrungen
- mit Hartmetall-Messflächen ab 12 mm
- Digital-Anzeige um 90° drehbar, mit ON/OFF/SET-, HOLD-, mm/inch/Mod-Taste
- mit Datenausgang Bluetooth

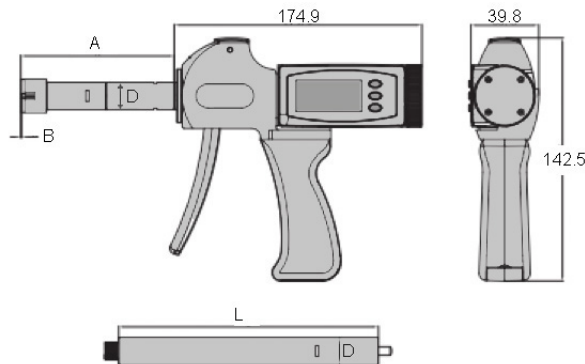

Achtung: Einstellring und Verlängerung gehören nicht zum Lieferumfang!

- *for blind hole*
- *with carbide measuring faces from 12 mm*
- *display rotatable up to 90°*
- *with on/off/set, hold, mm/inch/Mod button*
- *with data output Bluetooth*

attention: setting standard and extension not included

Art.-Nr. <i>Item no.</i>	Messbereich <i>Range mm</i>	Messkopf <i>Meas. head</i>	Teil-Messbereich <i>Part range mm</i>	B <i>mm</i>	A <i>mm</i>	D <i>mm</i>	Ableseung <i>Reading mm</i>	Genauigkeit* <i>Accuracy* µm</i>	Euro/Satz <i>Euro/pc</i>
312.324.O	6 - 12	3	6 - 8	1,5	75	5,8	0,001	0,004	
			8 - 10	1,5					
			10 - 12	1,5					
312.325.O	12 - 20	2	12 - 16	0,5	100	11,8	0,001	0,005	
			16 - 20						
312.326.O	20 - 50	4	20 - 25	0,5	90	105	0,001	0,005	
			25 - 30		90				
			30 - 40		105				
			40 - 50		105				
312.327.O	50 - 100	4	50 - 63	0,5	105	23,5	0,001	0,005	
			62 - 75						
			75 - 88						
			88 - 100						

VERLÄNGERUNGEN
EXTENSIONS

* Bei vollanliegenden Messflächen!
** at full contact of the measuring faces!*



Art.-Nr. <i>Item no.</i>	für Messkopf <i>for Meas. head</i>	D <i>mm</i>	L <i>mm</i>	Gewinde <i>Thread mm</i>	Euro/Stk. <i>Euro/pc</i>
312.330	6 - 8, 8 - 10, 10 - 12	5,8	101,6	M 5	
312.331	12 - 16, 16 - 20	11,8	152,4	M 8	
312.332	20 - 25, 25 - 30	15,8	152,4	M 10	
312.333	30 - 40, 40 - 50	23,5	152,4	M 18	
312.334	50 - 63, 62 - 75, 75 - 88, 87 - 100	23,5	152,4	M 21	